



Flexible Product Development

Learning from Agile Software

John Farnbach
Silver Streak Partners LLC
john@silverstreakpartners.com

Silver Streak Partners LLC

© 2010 all rights reserved

Flexible Hardware Development

IS NOT:

- ◆ Developing flexible hardware
- ◆ Full vs. light Stage Gate

IS:

- ◆ Embracing change
- ◆ Keeping the plan flexible
- ◆ Mid stream learning



Business Value of Agile?



Agile Software Development

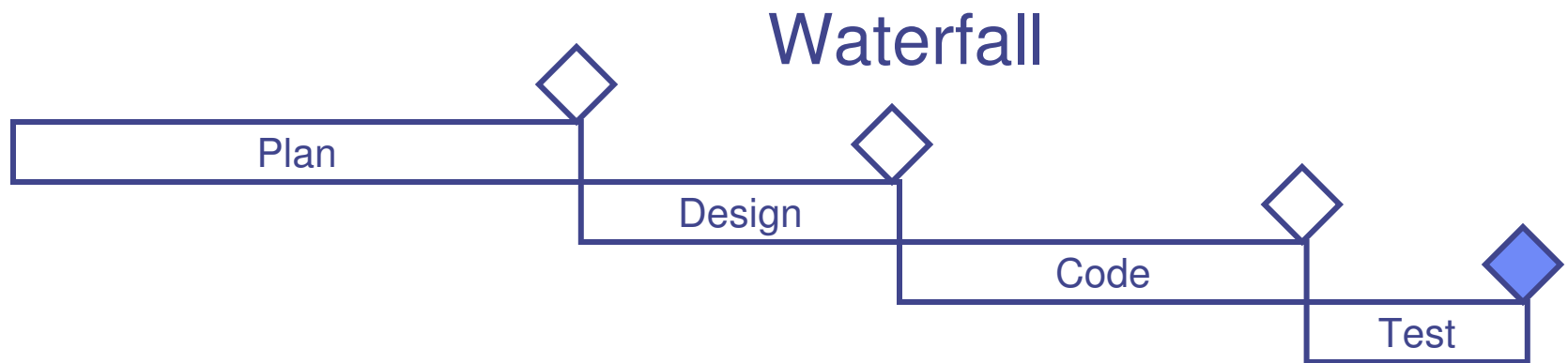

Agile (XP, SCRUM, Crystal, FDD, Kanban?)

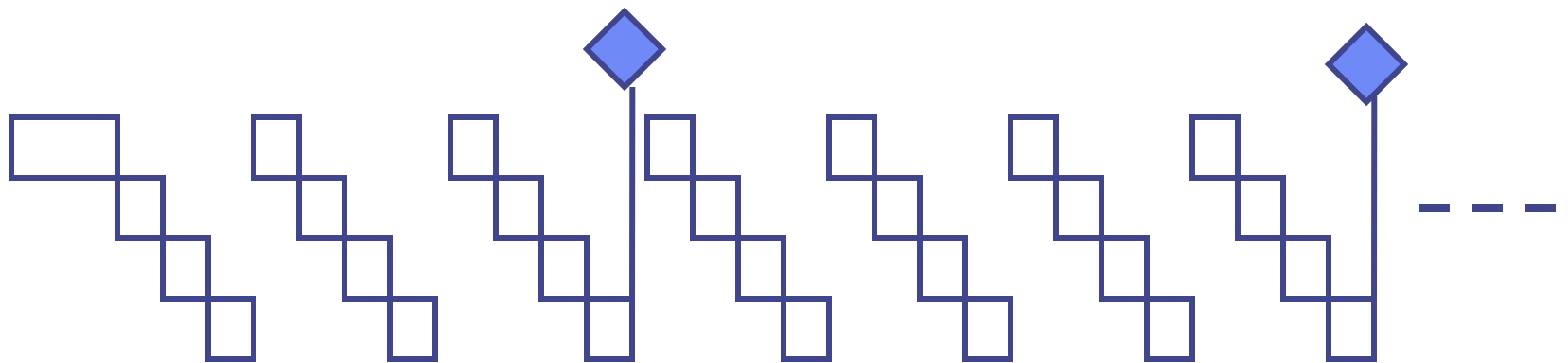

Agile Software Principles

Planning paradigm	Delay decisions until iteration starts
Object-oriented coding	Change tolerant architecture
Short iterations	Fast feedback and accelerated learning
Emergent process	Shape process to meet project needs
Teams and people	People factors outweigh process and tools
Implementing Agile	Organizational change

Embracing Change

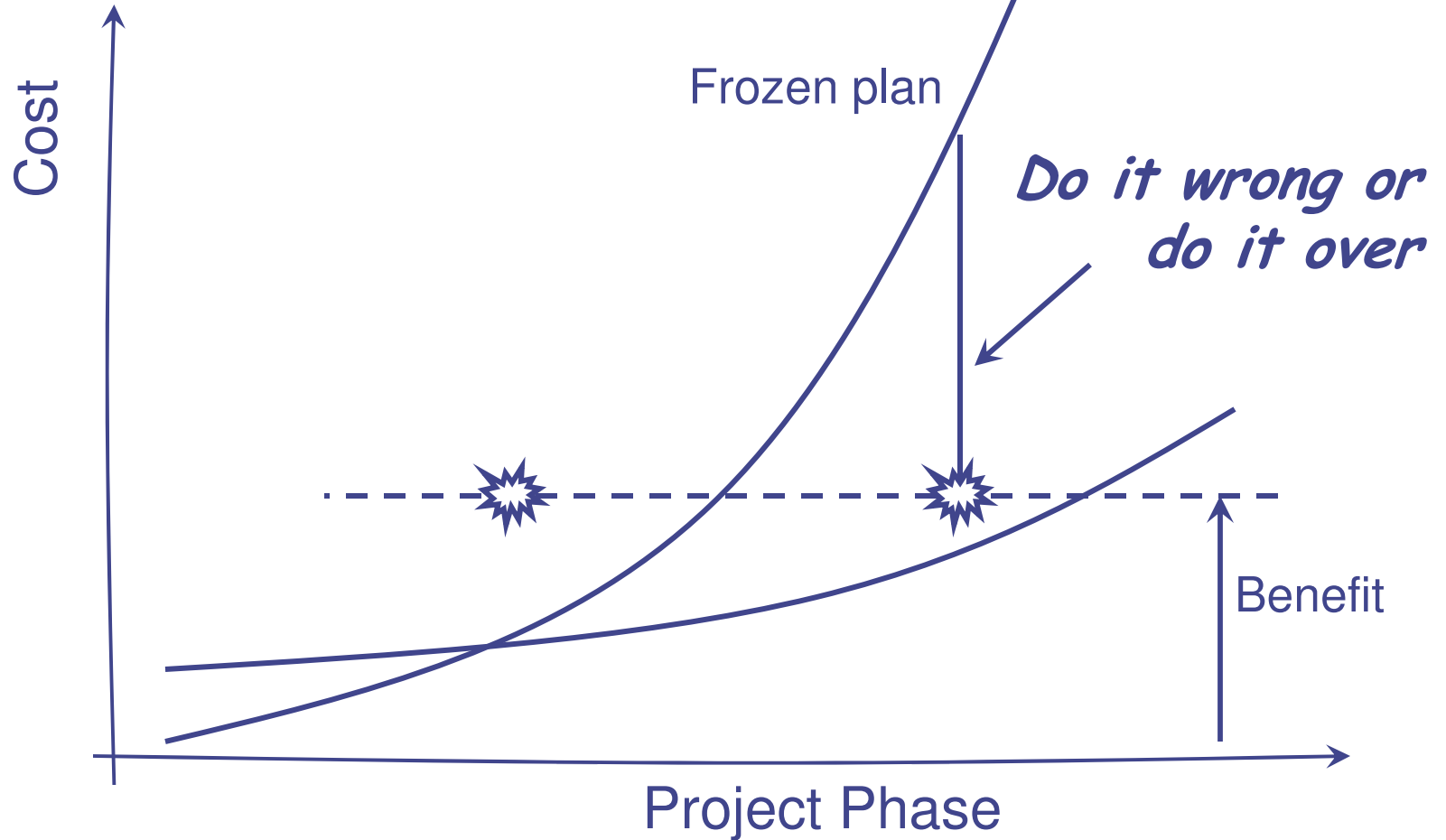

Delayed Decisions

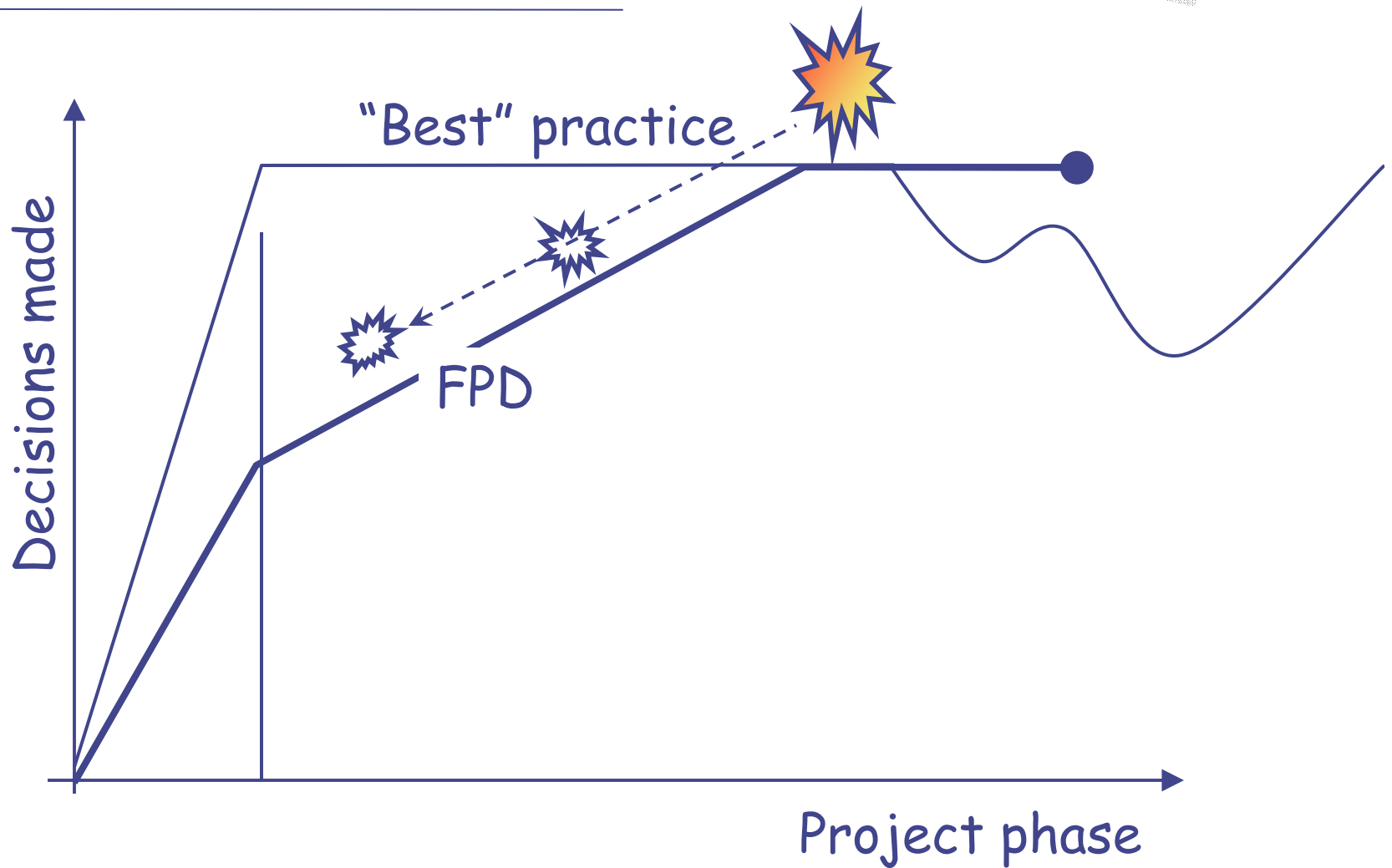

Last Responsible Moment

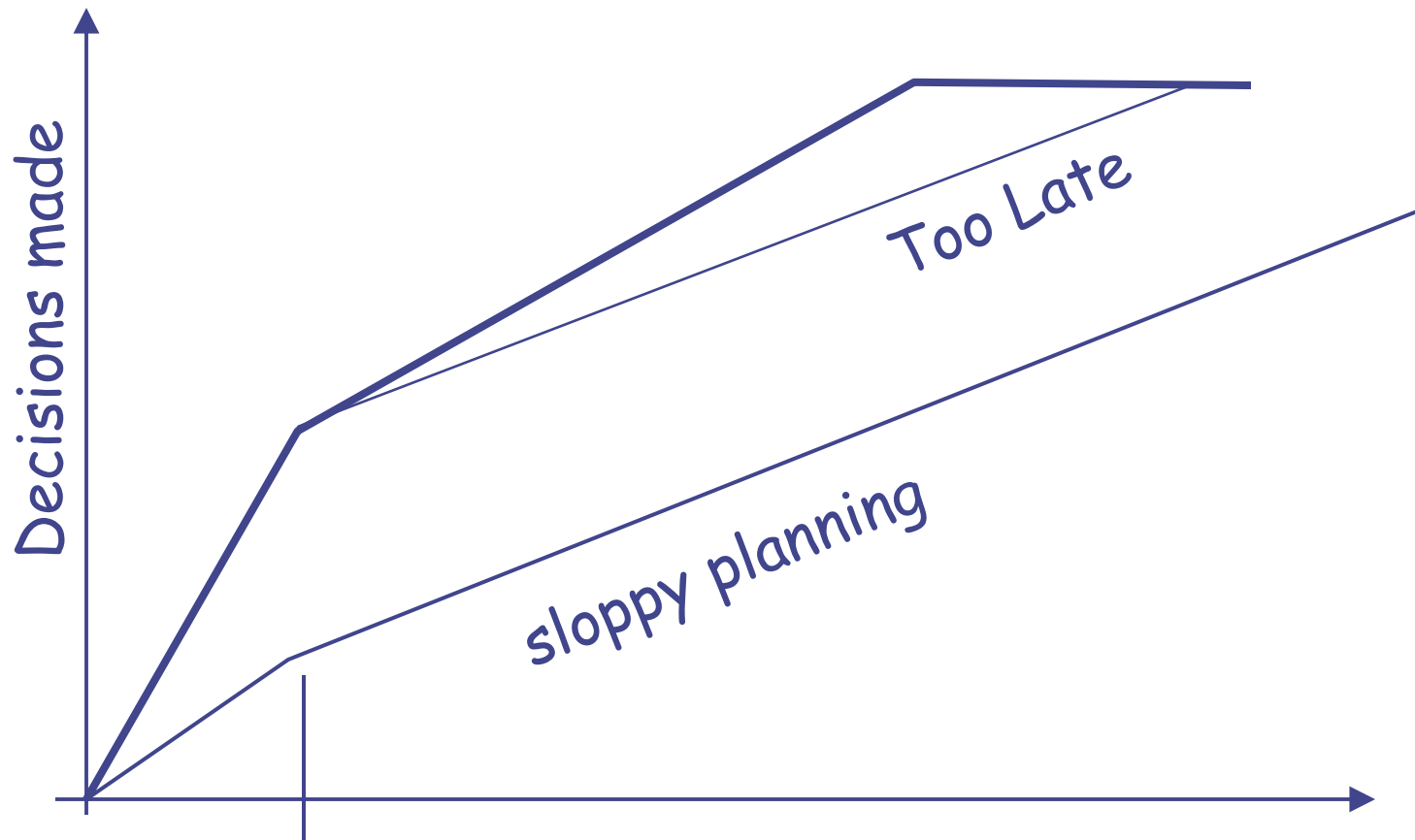



Delay Decisions



Change Tolerant Architecture

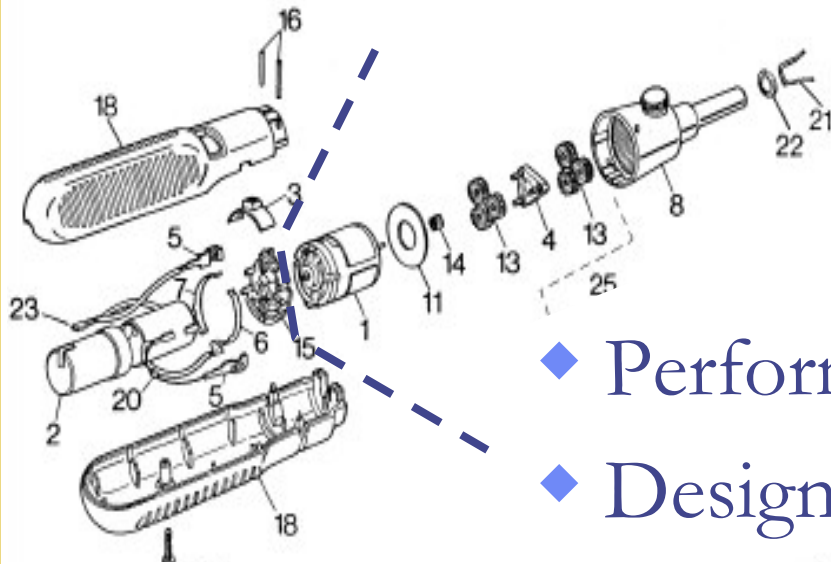
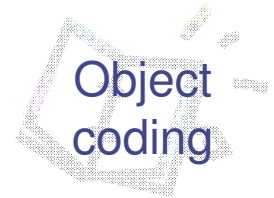

- ◆ Performance, cost, etc.
- ◆ Design flexibility
 - “Fence in” change
 - Align w/organizational boundaries

Hardware, firmware boundaries

Accelerated Learning



- ◆ Front-loaded prototyping
 - Many, not few
 - Low cost, quick builds
 - Frequent customer review
- ◆ Early experimentation
 - Speculate-try-adapt
 - Seek out disconfirming evidence
- ◆ Learning, not verification!

Process Changes



- ◆ Exploration – develop and try
- ◆ Barely sufficient standardization
- ◆ Shift from flexible to structured over project life.

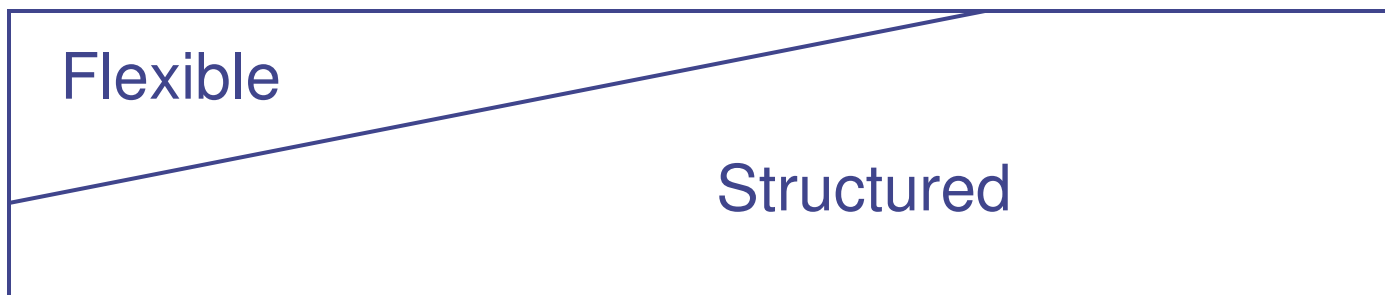



Emergent Process



Silver Streak Partners LLC

© 2010 all rights reserved

Get the Right Team



Performance Impact

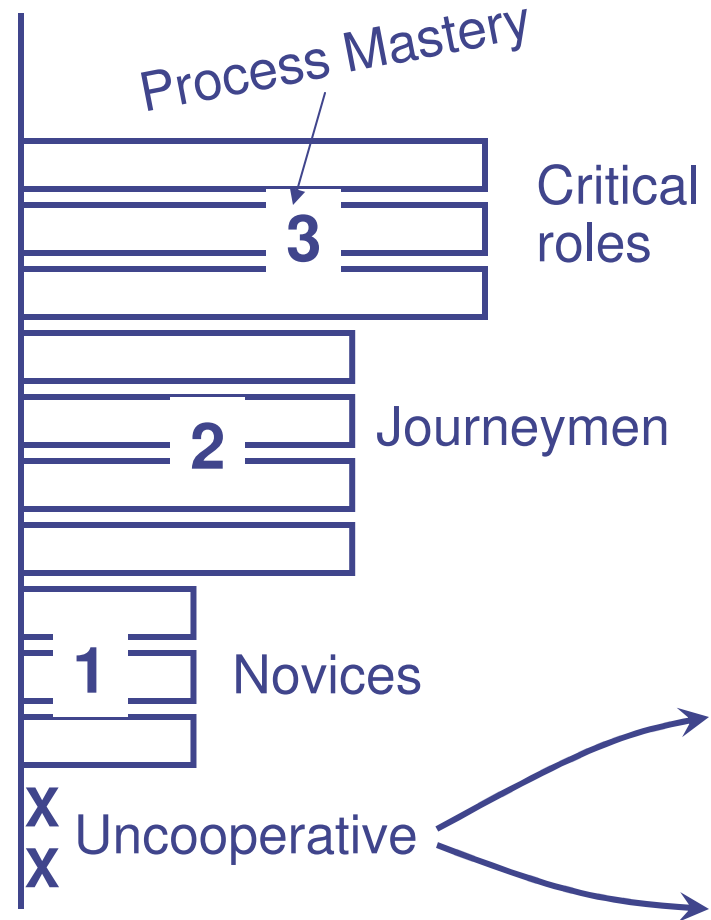
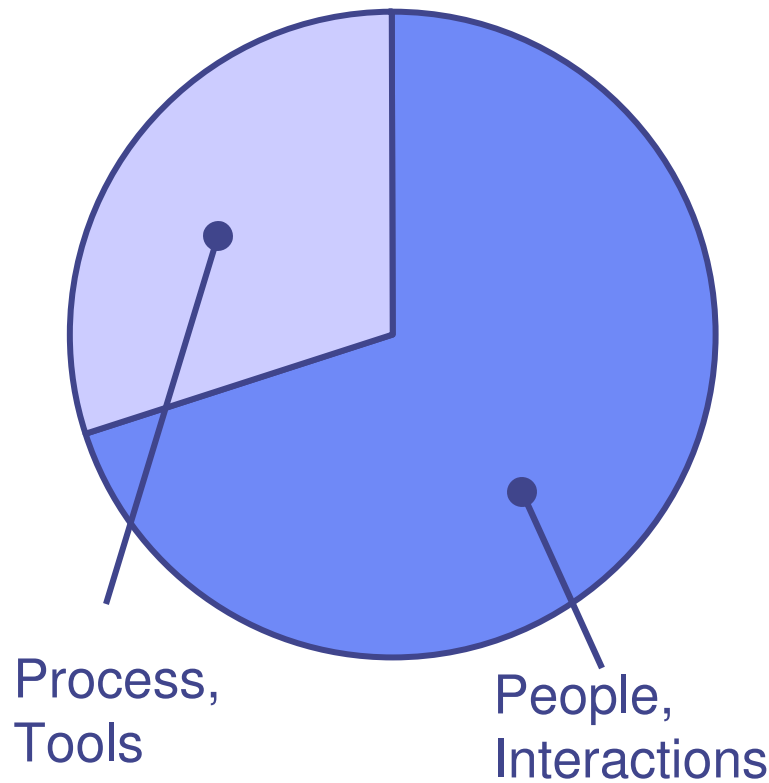

Communication



- ◆ Co-located – 30 ft.
- ◆ Social skills – respect & support
- ◆ Fluid communications – daily (?) stand-ups
- ◆ Dedicated people – full time
- ◆ Generalists – multiple roles

- ◆ Partially co-located?
 - Team focus on communication processes
 - Email, file sharing not sufficient!
 - In-person meetings: planning, kickoff, status
 - Frequent virtual meetings

Implementing Flexibility

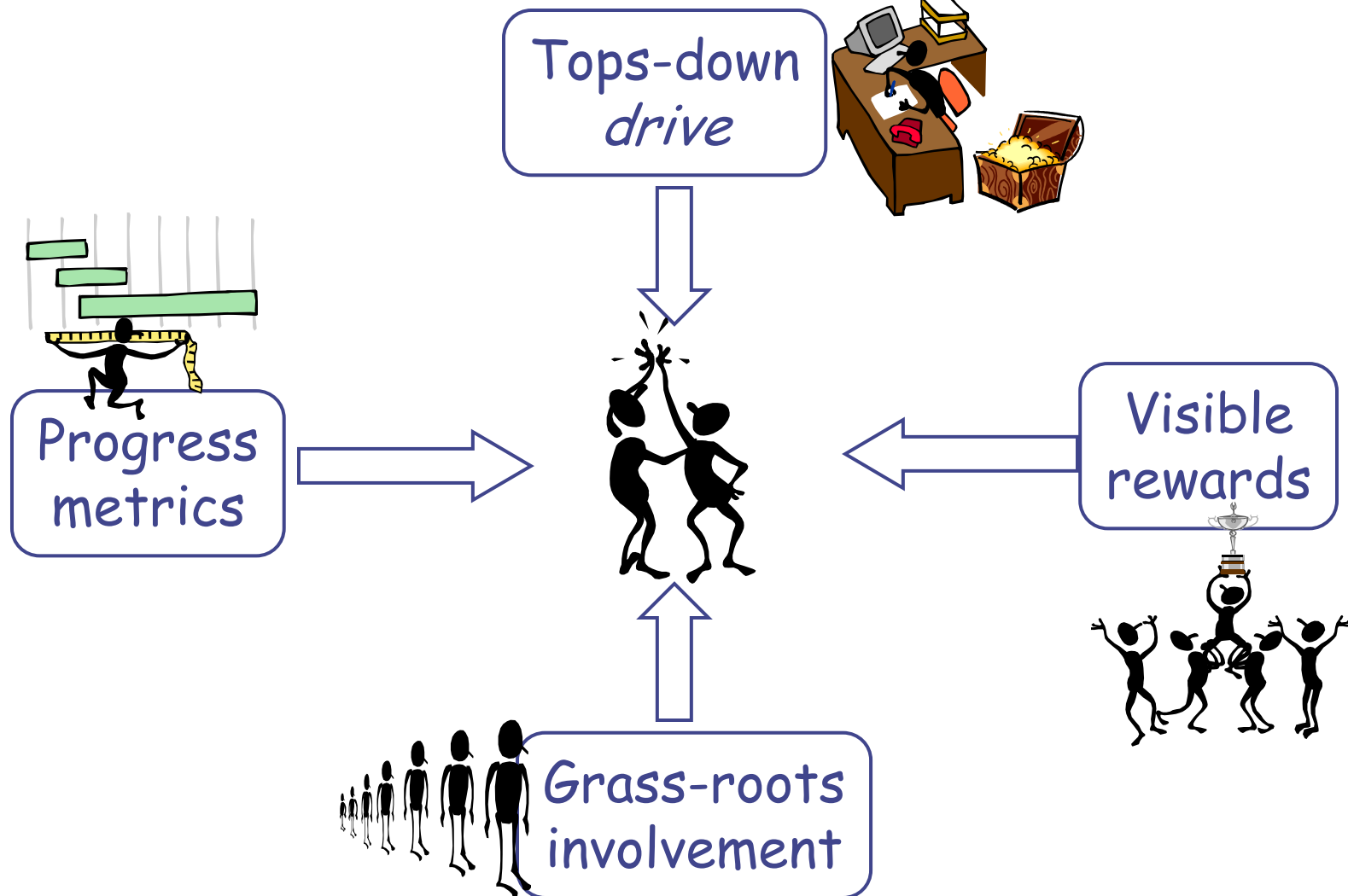

Silver Streak Partners LLC

© 2010 all rights reserved



Implementation Hurdles?



Questions & Discussion

John Farnbach

john@silverstreakpartners.com

Silver Streak Partners LLC

www.silverstreakpartners.com

Blog: <http://silverstreakpartners.com/BetterNPD/>

Silver Streak Partners LLC

© 2010 all rights reserved